

Functionality and Benefits

PHANTOM 770

The **PHANTOM 770** is one of the strongest two-shaft shredders in its class and can be used for many different applications.

It can shred many types of materials such as wood, waste, stone, tires, light scrap and many more. The material is fed from above, drawn in reliably and shredded continuously by two powerful, slow-moving shafts. The final output size can be easily selected by adjusting the screen baskets and the discharge belt ensures continuous material output. The robust track chassis provides excellent stability and mobility – even on demanding terrain.

The optional overbelt magnet reliably separates ferrous materials, improving the quality of the final product.

Due to the fastest shaft change system on the market and minimal setup times, the **PHANTOM 770** offers maximum flexibility – perfect for working with different materials.

The effective volume reduction saves space, lowers transport costs and prepares the material well for the next processing steps.

PHANTOM 770 – powerful, flexible and reliable. Made in Germany.



Engine and Drive Configurations

PHANTOM 770



STANDARD

205 kW Diesel engine



PLUS

310 kW Diesel engine



HYPERION

250 kW Electric motor
18,4 kW Diesel drive system



STANDARD EQUIPMENT

- » Water spraying system
- » Hopper extension
- » Replaceable wear plates
- » Reversing fan
- » Remote control
- » Hot-dip galvanized discharge belt

OPTIONS

- » Magnet with hydraulic height adjustment
- » GSM module (remote maintenance)
- » Track pads
- » Winter package
- » Various shaft configurations
- » Various breaker bars

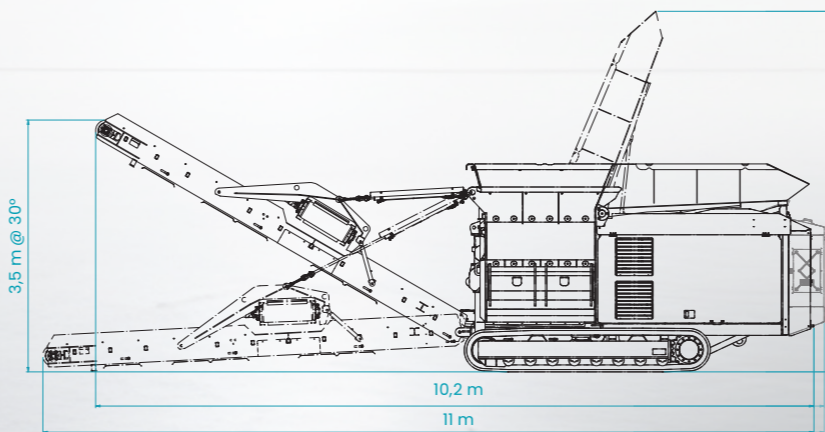
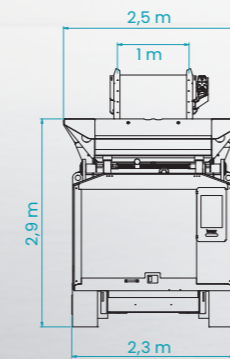

„MANY DEMANDS. ONE MACHINE. NO COMPROMISES!“

... the WERT PHANTOM 770

INNOVATIONS PREIS THÜRINGEN
PREISTRÄGER WINNER 2025



PHANTOM 770
WERT GmbH
YOUTUBE

RECYCLING TECHNOLOGY – MADE IN GERMANY



INNOVATIONS PREIS THÜRINGEN
PREISTRÄGER WINNER 2025



PHANTOM 770

Any questions? Contact us ...

WERT GmbH
Ölmühle 8 · 98597 Fambach
Germany

Telefon: +49 36848 275615
E-Mail: info@wert-service.com
Internet: www.wert-service.com

DEALER



THE PHANTOM 770 EASILY SHREDS MATERIALS SUCH AS WOOD, WASTE, STONE AND LIGHT SCRAP, ...

The material is fed from above, drawn in by the shafts and continuously shredded.

The steplessly height-adjustable discharge belt reliably transports the shredded material.

The tilting hopper ensures optimal feeding and can be tilted up to 90°.

The steplessly height-adjustable magnet belt automatically separates ferrous materials sideways.

The tracked chassis provides excellent stability and mobility – even on demanding terrain.

PHANTOM 770

SHAFTS

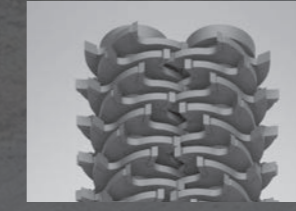

STAR SHAFT
Old wood, root-stocks, tires, commercial waste, paper, waste, sandwich panels, plastics

VARIABLE OUTPUT SIZE



COMBINATION SHAFT
Wood, waste, tires, timber, green waste, root-stocks, paper

DEFINED FINAL OUTPUT SIZE



HAMMERSHAFT
Reinforced concrete, concrete, construction debris, stone

VARIABLE OUTPUT SIZE



METAL SHAFT
Light scrap, concrete railway sleepers, window profiles, sandwich profiles

VARIABLE OUTPUT SIZE

MATERIAL	THROUGHPUT*
Construction debris	Ø 180 - 220 t/h
Old wood	Ø 35 - 42 t/h
Green waste	Ø 25 - 35 t/h
Commercial waste	Ø 18 - 25 t/h
Rubber	Ø 13 - 18 t/h
Root stocks	Ø 22 - 30 t/h
Paper	Ø 12 - 19 t/h

*The listed performance values are average figures and are provided without guarantee. They may vary depending on the shaft configuration, the selected screen basket settings and optimal material feeding.

ADVANTAGES OF THE PHANTOM 770

- » Maximum application range thanks to flexible shaft configurations – designed for a wide range of materials and final output sizes – even without reconfiguration
- » Compact, modular and service-friendly design
- » Extremely short setup times thanks to the fastest shaft change system on the market
- » Worn shafts can be rotated easily to almost double their service life (hammershafts)
- » PLC control – latest generation with remote maintenance capability – optional app integration
- » Gearbox available in synchronous or asynchronous
- » Transport without special permits



ENGINE
The PHANTOM 770 is available with different engine and drive options.

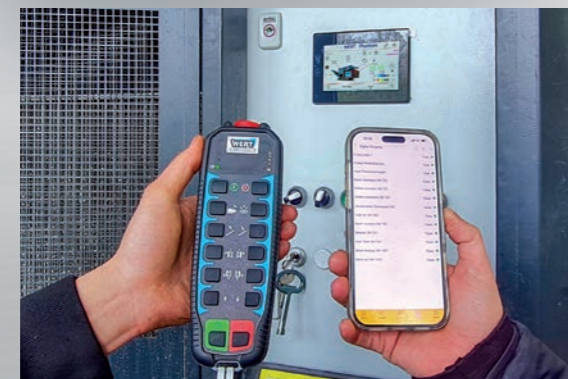

CONTROL PANEL
Modern PLC control for operating, monitoring and managing all functions – optional app integration.



SCREEN BASKET ADJUSTMENT
The screen basket adjustment allows quick and flexible adaption of the final output size.



QUICK-CHANGE SYSTEM
Innovative shaft change system with a rotation function for extended service life of hammershafts.



SHAFTS
Various shafts available for different applications.